

# Hottap V1

## Mount bracket cutout instructions

- 1** Remove the handle.  
*Note: To access the internal nuts, remove the top panel and replace before moving to step 2.*

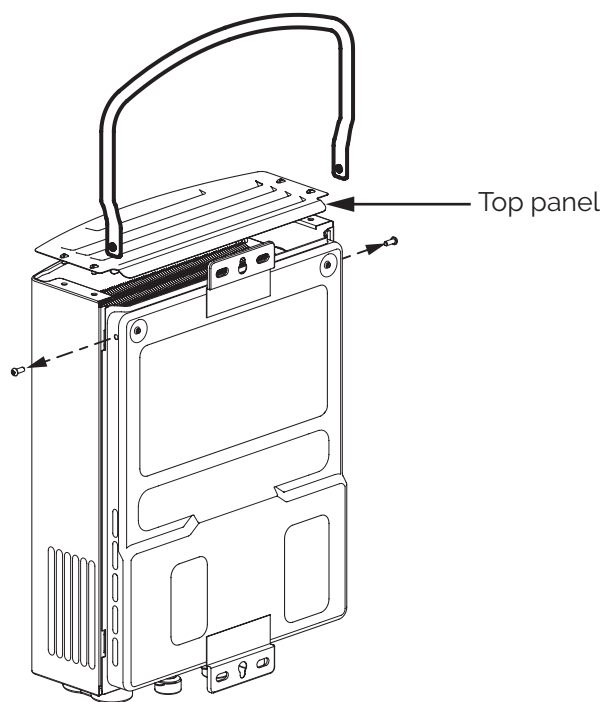

- 2** Remove the top and bottom mounting brackets.  
*Note: Skip step 2 if your unit does not have these mounting brackets.*

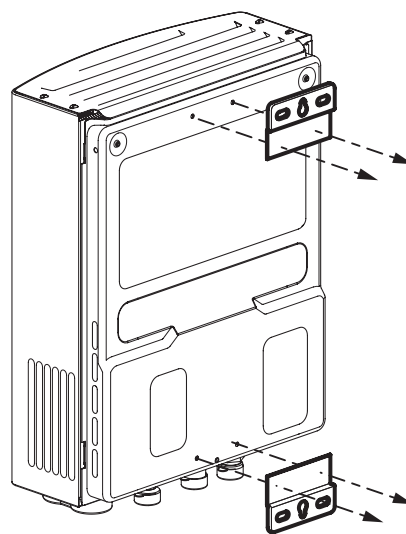

- 3** Cut slots into rear panel.\* Spray edges with anti-rust coating.  
*See page 2 for dimensions*

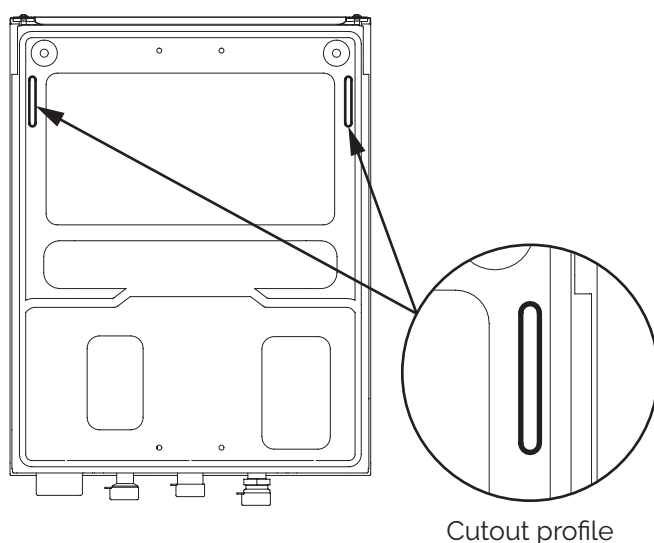

- 4** Cut slots into bottom panel.\* Spray edges with anti-rust coating.  
*See page 2 for dimensions*

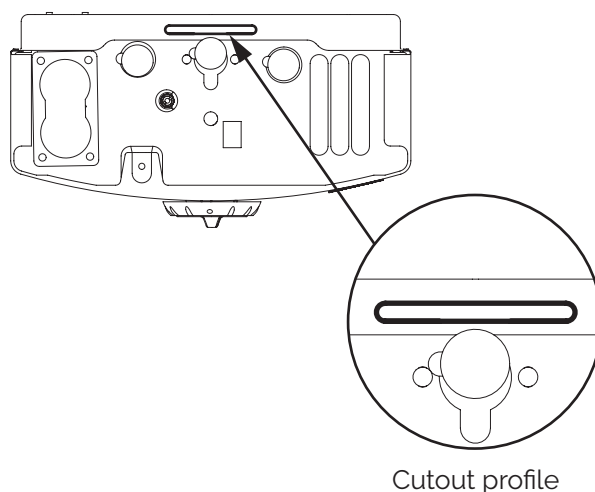

### \*WARNING

- When cutting slots be careful to avoid cutting internal plumbing



# Hottap V1

## Cutout dimensions

### 3 Rear panel cutouts

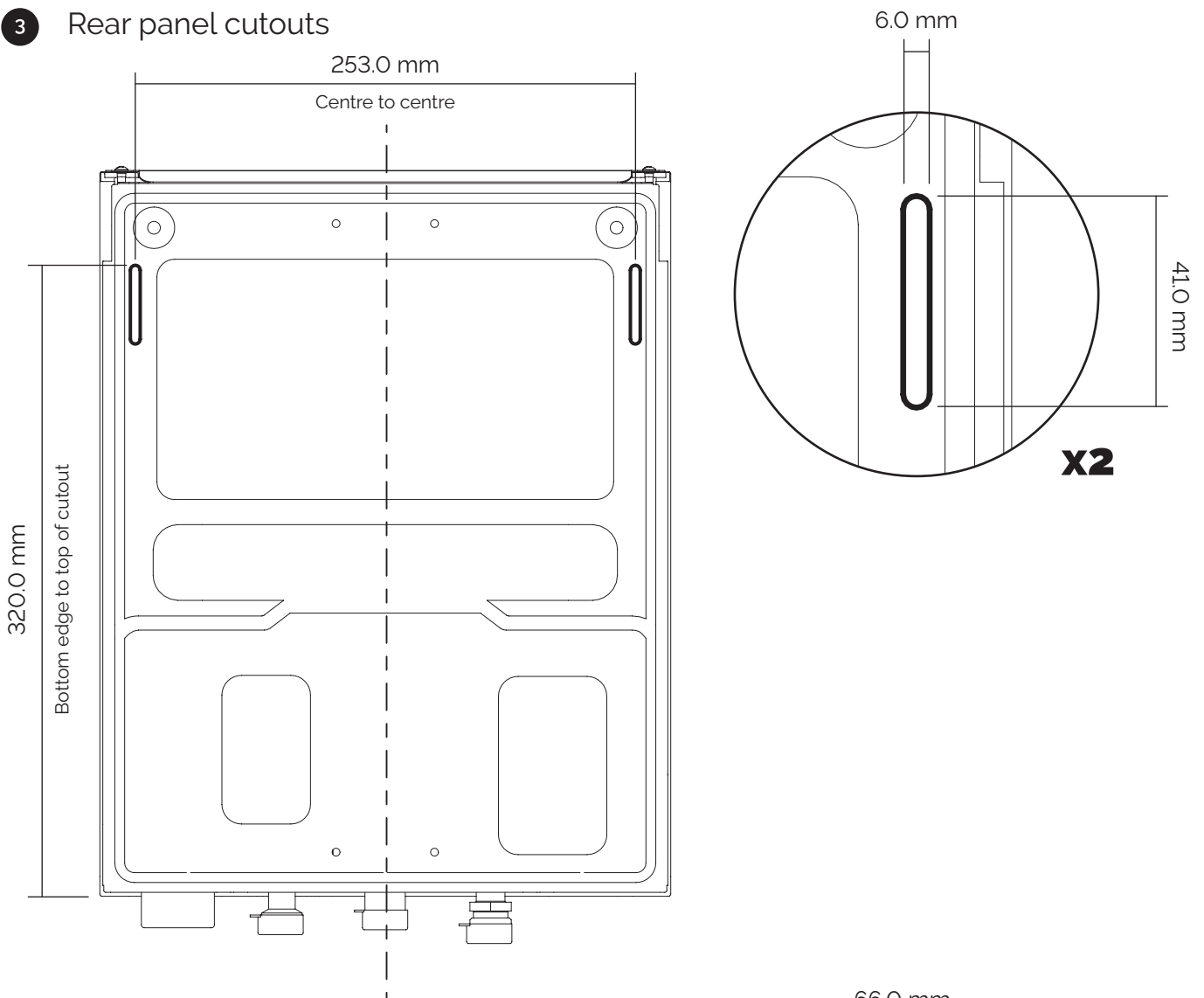

### 4 Bottom panel cutouts

